

DIRECT FIRED AIR/GAS STREAM HEATERS SERIES MIXBLOC



MIXBLOC TG Air Stream Burners for heat boost on oxygen rich gas turbine exhausts gas exit, low pressure drop, high turndown ratio.



MIXBLOC TG Combustion air taken from process gas stream. Internal burner operating at 250°C. Pressurised gas circuit.



MIX Typical cross section of a MIX Series Air Stream Burner sized to suit duct

**“120 years of Babcock – 72 years of Wanson – 45 years of Wanson UK
There is no substitute for experience”**

Babcock Wanson UK Ltd 7 Elstree Way Borehamwood Hertfordshire WD6 1S UK

Tel: +44 (0)20 8953 7111 Fax: +44 (0)20 8207 5177 email: wanson@babcock-wanson.co.uk www.babcock-wanson.com
Sales and Production facilities in France, Italy, Morocco, Central Europe, Portugal, Spain, Switzerland and UK

AFTER SALES SERVICE As with all Babcock Wanson products, this Process Air Heater range is fully supported by our world wide After Sales Operation for service and spares, staffed by trained and qualified engineers to ensure life time care for the products and systems.

- **MIXBLOC** Air and Gas Stream Burners are constructed from Vee elements assembled in any shape to suit load and duct shape.
- Output range kcal/h (kW)
100,000 – 30,000,000 (116 – 34,890)
- Modulation range is 10/20:1.
- Max gas outlet temp 800°C.
- Fuels may be natural gas, bio gas, LPG or manufactured gas.
- May be used for gas clean up VOC & odour destruction.
- Combustion air may be from the heated gas stream or via a separate external forced fresh air supply. The burner assemblies may be placed in the gas stream (EI) <400°C on temperature or external (EE) for >400°C.
- The **MIXBLOC** series of burners may be arranged horizontally, vertically and may be positioned upstream or downstream of the fan.

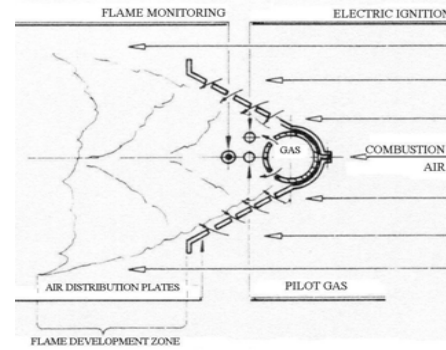

SCHMATIC OF AIR/GAS STREAM BURNER

MIXBLOC DESIGN ALTERNATIVES

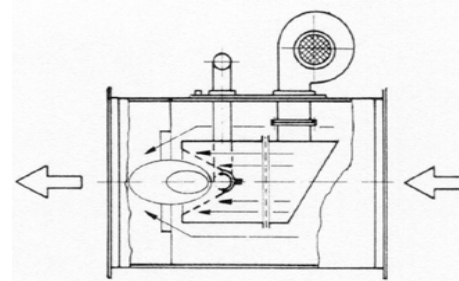

MIXBLOC EI
EXTERNAL COMBUSTION FAN INTERNAL BURNER

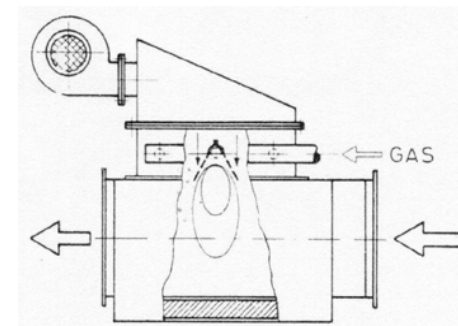

MIXBLOC EE
EXTERNAL BURNER & COMBUSTION AIR FAN

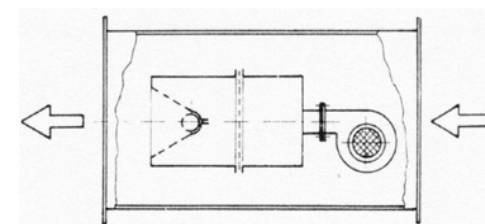

MIXBLOC II
INTERNAL BURNER & COMBUSTION AIR FAN
(For lower inlet air/gas temperatures)

PROCESS AIR HEATERS - DIRECT AND INDIRECT



DIRECT Gas or oil fired Process Air Heater for the spray drying of ceramic and other materials.

- Ceramics
- Clay
- Printing, coating and laminating
- Industrial Abrasives
- Composite material curing
- Ejector diffuser space heating
- Fertiliser production
- Cement production
- Laminate curing
- Active carbon regeneration etc

INDIRECT gas or oil fired air heaters for medium and high temperatures.

- Tobacco
- Food processing
- White ceramics
- Meal, grain, fibre
- Pharmaceuticals
- Ejector diffuser Space Heating
- Sugar refining
- Milk drying
- Print drying
- Laminate curing



MIXBLOC Model EE2500 Gas Stream Burner with separate external burner and combustion air fan. High pressure for fluidised bed activation.



BABCOCK WANSON PRODUCTS include – Steam Boilers, Steam Generators – Thermal Fluid Heaters & systems, VOC and Odour Destruction Equipment – Water Treatment Plant, Cabinet and Unit Heaters for Space Heating.

Turnkey contracts for complete plants – All Babcock Wanson products are progressively developed through top class R & D and backed by the International CNIM Energy Group.

INDIRECT FIRED PROCESS AIR HEATERS SERIES HTV & MTV

TYPE	HTV	MTV
Thermal Capacity kcal/h (kW)	500,000 – 2,000,000 (581 - 2326)	150,000 – 2,000,000 (175 – 2326)
Air Flow Range Nm ³ /h	6,800 – 28,000	3,600 – 48,000
Temperature Range °C	20 – 300	20 – 300
Maximum Δt °C	230	130
Efficiency	87%	87%
Normal max. ΔP mm w.g.	90	45
Configuration	Horizontal	Horizontal
Combustion Chamber	Stainless Steel	Stainless Steel
Modulation	4:1	4:1
Fuel	All liquid and gaseous	All liquid and gaseous

DIRECT FIRED PROCESS HEATERS SERIES GASAIRBLOC

Thermal Capacity kcal/h (kW):	100,000 – 15,000,000 (116 - 17,445) Larger outputs available custom designed
Maximum Outlet Temp:	1200°C
Modulation Range:	4:1
Fuels:	All liquid and gaseous fuels
Configuration:	Horizontal or Vertical
Efficiency:	100% less any system losses.
Normal Max ΔP mm w.g.	20 – 30
Combustion Chamber	Refractory lined

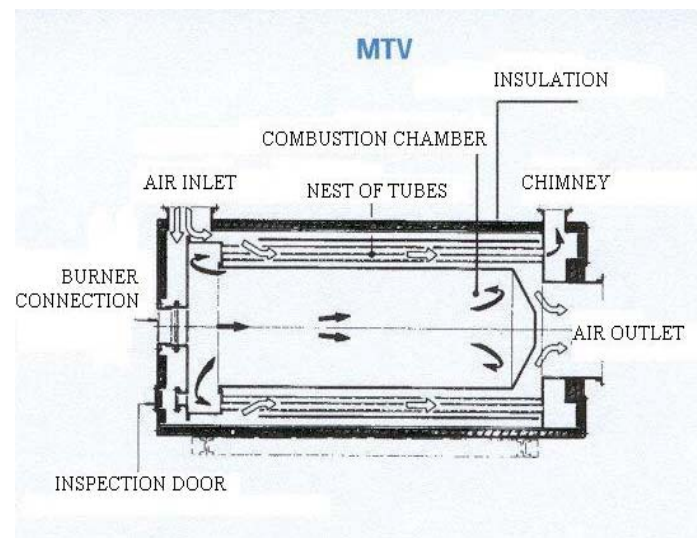
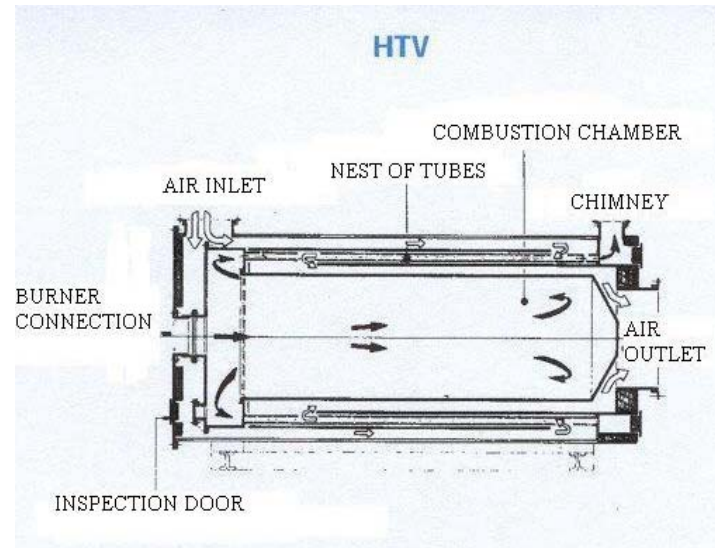

- **HTV & MTV** heaters are used for applications where pure air is required at the process. The heaters are supplied fully packaged with electrical control cabinet to suit application and ready to connect to site services. The main system air fan may be sited upstream or downstream of the heater.
- Burners fitted to **HTV & MTV** heaters are of advanced design and construction and enable the equipment to be built to comply with emission levels regulated by European and International Directives. Babcock Wanson or other proprietary burners may be fitted.
- Economisers may be added for further efficiency enhancement and to recover low grade heat.

MULTI-TUBULAR HIGH EFFICIENCY DESIGN

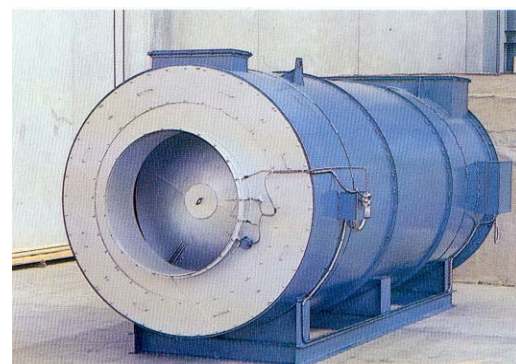

Gas fired HTV Model 2000 – Milk Drying – Air Outlet 250°C
(view on air outlet end)

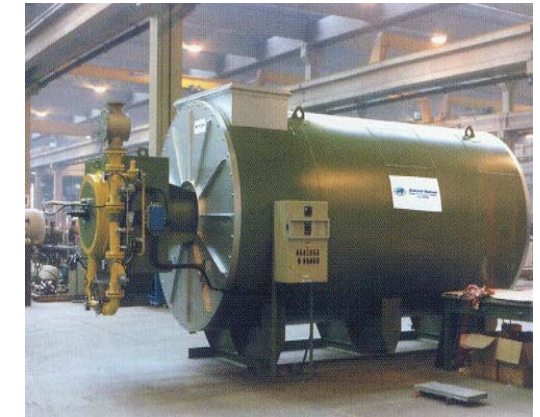
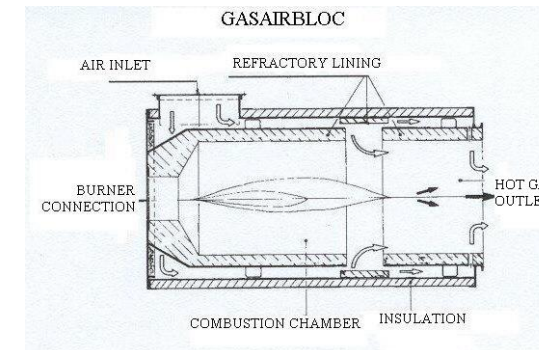

Gas fired - Gasairbloc Model 4000 GAB



Dual fuel – heavy oil/gas – Gasairbloc Model 3000 GAB

- Gasairbloc heaters are used where clean products of combustion are acceptable to the process application.
- Fully packaged, complete with controls, wiring and combustion equipment ready to connect to process and services.
- Refractory lined high temperature direct fired process heater for a wide range of industrial applications: drying, curing, setting etc.
- Babcock Wanson or other proprietary burners may be fitted.
- Suitable for use upstream or downstream from main fan.

FURTHER INFORMATION

For more data on any Babcock Wanson Product and for applications assistance for your process please contact us at the address overleaf

MOD	kcal/h	kW	GASAIRBLOC - GAB			MTV			HTV		
			A	B	C	A	B	C	A	B	C
150	150,000	175	2110	1020	1000	3230	1275	1225			
300	300,000	349	2315	1045	1025	3600	1723	1700			
400	400,000	465	2285	1200	1180	3870	1723	1730			
500	500,000	581	2480	1210	1190	4290	1947	1780	4800	1900	2020
750	750,000	872	2845	1330	1410	4490	2182	2123	5260	2075	2095
1000	1,000,000	1163	3240	1460	1440	5225	2218	2230	5715	2280	2350
1500	1,500,000	1744	3685	1700	1720	6085	2508	2600	6153	2620	2710
2000	2,000,000	2326	4180	1840	1860	6604	2842	2812	6835	2800	2900
2500	2,500,000	2907	4200	1970	1990						
3000	3,000,000	3489	4690	2020	2040						
4000	4,000,000	4652	5300	2265	2285						
5000	5,000,000	5815	5870	2425	2445						
6000	6,000,000	6978	6110	2570	2590						
8000	8,000,000	9304	6820	2855	2870						
10000	10,000,000	11630	7650	3125	3145						

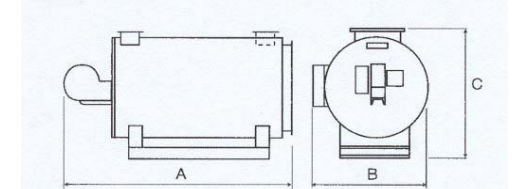

All dimensions and specifications approximate and subject to change without notice.